

CONWAY PLANNING BOARD

MINUTES

FEBRUARY 13, 2003

PAGES

- 1 Review and Acceptance of Minutes
 - January 23, 2003 – Adopted as Written
 - January 30, 2003 – Adopted as Written

- 1 Darrell and Elaine Umlah – Subdivision Review (PID 203-29) File #S03-01
 - Withdrawn by the Applicant

- 1 Furbush Realty, LLC – Minor Site Plan Review (PID 235-37) File #MR03-01
 - Continued until February 27, 2003

- 2 White Mountain Bioprogressive, LLC – Minor Site Plan Review (PID 218-66) File #MR03-02
 - Conditionally Approved

- 2 Roger Jones (PID 252-12) – Conceptual Review
 - Four Field Changes Approved

- 3 Public Hearing – Amendment Article 147-15.E.(3) – Accessory Dwellings
 - Posted to the Warrant pending legal review

- 3 Public Hearing – Amendment Article 147-15.E.(2) – Increase in Density
 - Posted to the Warrant pending legal review

- 4 Other Business
 - North Conway Country Club
 - Cranmore Mountain Resort
 - Master Plan Workshop – Set Dates

CONWAY PLANNING BOARD

MINUTES

FEBRUARY 13, 2003

A meeting of the Conway Planning Board was held on Thursday, February 13, 2003, beginning at 7:01 p.m. at the Conway Town Office in Center Conway, NH. Those present were: Chair, Sheila Duane; Selectmen's Representative, Gary Webster; Vice Chair, Robert Drinkhall; Martha Tobin; David Robinson; Planning Director, Thomas Irving; and Recording Secretary, Holly Meserve.

REVIEW AND ACCEPTANCE OF MINUTES

Mr. Briggs made a motion, seconded by Ms. Tobin, to approve the Minutes of January 23, 2003 as written. Motion unanimously carried.

Mr. Briggs made a motion, seconded by Ms. Tobin, to approve the Minutes of January 30, 2003 as written. Motion unanimously carried.

DARRELL AND ELAINE UMLAH – SUBDIVISION REVIEW (PID 203-29) FILE #S03-01

The applicant withdrew the application.

FURBUSH REALTY LLC – MINOR SITE PLAN REVIEW (PID 235-37) FILE #MR03-01

Shawn Bergeron appeared before the Board. Mr. Briggs stepped down at this time. Mr. Bergeron stated staff had not had a chance to review changes to the plans at the last meeting and he has since discussed the changes with staff. Mr. Bergeron stated that the Town Engineer's primary concern is that the slope leading from the lower existing parking area to the upper is an 18% grade. Mr. Bergeron stated that the standards allow a maximum of % and the Town Engineer will not support the waiver.

Mr. Bergeron stated to make this work the applicant would have to cut two-feet of fill and it would cost the applicant approximately \$30,000 for the additional parking spaces. Mr. Bergeron asked the Board to give some thought to the regulations, as some of them just don't make sense. Mr. Bergeron stated that this slope could be compared to Duprey Road, the Red Jacket driveway and Guildes' Restaurants driveway. Mr. Bergeron stated that the regulations are requiring a small business owner to do something ridiculous when we have situations that we drive over every day.

Ms. Tobin asked if the only concern is the danger of that slope. Mr. Bergeron answered in the affirmative. Mr. Irving stated that there are erosion issues as well. Mr. Bergeron stated that we are also dealing with an existing situation that is over 20 years old. Mr. Briggs stated that it has not been a serviceable road over that entire time. **Mr. Drinkhall made a motion, seconded by Ms. Tobin, to continue until February 27, 2003. Motion unanimously carried.**

WHITE MOUNTAIN BIOPROGRESSIVE, LLC – MINOR SITE PLAN REIVEW (PID 218-66) FILE #MR03-02

Mr. Briggs rejoined the Board at this time. Shawn Bergeron of Shawn Bergeron Technical Services appeared before the Board. Mr. Bergeron stated that this property has received a special exception to convert the upper floor into apartments and the lower floor to remain as office space. Mr. Bergeron stated that the applicant would like to build a deck and stairs at the back of the building in order to have access to the upper apartments. **Mr. Briggs made a motion, seconded by Ms Tobin, to accept the application of White Mountain Bioprogressive, LLC for a minor site plan review as complete. Motion unanimously carried.**

Mr. Irving stated that this is before the Board because of the reduction in green space. Mr. Irving stated that the Board might want to give consideration to changing that requirement as reducing the greenspace by 200 square feet is not a whole lot. Mr. Irving stated that these stairs are for emergency egress. Mr. Robinson questioned note #10. Mr. Bergeron stated under the site plan regulations, building and parking are considered disturbed area.

Mr. Irving stated that since the parking spaces are in the Town's right-of-way the Board and the Board of Selectmen have required a license. Mr. Irving stated that staff has no issues with the waivers as long as the license is acquired and all legal fees paid.

Ms. Duane read the requirement to grant a waiver. Ms. Duane read a waiver request for Articles 123-20.C; 123-20.I; 131-67.C.8.a; 131-67.C.8.c.; 131-67.C.8.f.; 123-20.G.; 123-21.; 123-22.E.; 123-27.; 29.A.(2) & (3); 123-29.D.(8); and 123-30. **Mr. Drinkhall made a motion, seconded by Mr. Webster, to grant the waiver requests for Articles 123-20.C; 123-20.I; 131-67.C.8.a; 131-67.C.8.c.; 131-67.C.8.f.; 123-20.G.; 123-21.; 123-22.E.; 123-27.; 29.A.(2) & (3); 123-29.D.(8); and 123-30.. Motion unanimously carried.**

Mr. Briggs made a motion, seconded by Mr. Drinkhall, to conditionally approve upon a sign indicating the handicap space installed; secure license with the town for uses in the right-of-way; when the conditions have been met, the plans can be signed out-of-session; and this conditional approval with expire on May 8, 2003. Motion unanimously carried.

ROGER JONES (PID 252-12) – CONCEPTUAL REVIEW

Shawn Bergeron of Shawn Bergeron Technical Services appeared before the Board in regard to J & J Floor Covering. Mr. Bergeron stated that the building was constructed and a conditional certificate of occupancy issued. Mr. Bergeron stated that they are trying to clean up the approval in order to obtain a certificate of occupancy with no conditions.

Mr. Bergeron showed the Board the four changes to the plans from the original site plan approval. Mr. Bergeron stated that the concrete retaining wall was not on original site plan, which removed two parking spaces from the original approval. Mr. Irving stated that the original plan did not have a door there and when the door was added they needed a way to get to it.

**Adopted: February 27, 2003 – As Written
CONWAY PLANNING BOARD – FEBRUARY 13, 2003**

Mr. Bergeron stated that there was a relocation of a light fixture on the side of the building. Mr. Bergeron stated that four fluorescent light fixtures on the front that was not on the original approval. Mr. Bergeron stated that the regulation is for light not to spill off the property. Mr. Irving stated that a shield could help. Mr. Bergeron agreed. Mr. Bergeron stated that there was not a light on the garage on the original plan and a light has been installed. Mr. Irving stated that he doesn't have an issue with the lighting on the side and the back or the ramp. Ms. Duane stated that she has never seen the parking lot fully used. Mr. Irving stated that loss of two spaces does not have an impact on the site.

Mr. Briggs made a motion, seconded by Mr. Drinkhall, to accept the four changes as a field change with the front fluorescent lights being shielded. Motion unanimously carried.

PUBLIC HEARING – AMENDMENT 147-15.E.(3) – ACCESSORY DWELLINGS

A public hearing was opened at 7:45 p.m. Ms. Duane read the proposed amendment. Ms. Duane asked for Board comments; there was none. Ms. Duane asked for public comment; there was none. Mr. Robinson commented that the Zoning Board of Adjustment would be very busy. The public hearing was closed at 7:47 p.m. **Mr. Webster made a motion, seconded by Ms. Tobin, that amendment to Article 147-15.E.(3) as written be submitted to the Town Clerk to be posted to the Town Warrant subject to legal review. Motion unanimously carried.**

PUBLIC HEARING – AMENDMENT 147-15.E.(2) – INCREASE IN DENSITY

A public hearing was opened at 7:48 p.m. Ms. Duane read the proposed amendment. Ms. Duane asked for Board comments; Mr. Briggs stated that this serves a very good purpose, but he doesn't think this amendment will help work force housing. Mr. Briggs stated that this amendment would help sprawl. Ms. Duane asked for public comment; Shawn Bergeron stated out of 12 units only three has to be rental and nine can be condominiums. Ms. Duane answered in the affirmative and stated that this helps finance the project.

Mr. Bergeron stated that this will create condominiums and the numbers are backwards. Ms. Duane stated that they have to be backwards as it would not be affordable for a developer. Ms. Duane stated that this was the best way to get some sort of housing. Mr. Bergeron stated that most condominiums are rented than lived in full-time. Mr. Bergeron stated that you can get more rent for a weekend then you can rent it full-time. Ms. Duane stated we couldn't put any more burdens on the Town and did not want to create a housing authority. Mr. Robinson stated that this seems to be unenforceable. Mr. Irving stated that the deed recorded at the registry would state which units could not be sold. Ms. Duane stated that they wouldn't be able to get a mortgage for the units not to be sold. The public hearing was closed at 7:59 p.m.

Mr. Briggs made a motion, seconded by Mr. Webster, that amendment to Article 147-15.E.(2) as written be submitted to the Town Clerk to be posted to the Town Warrant subject to legal review. Motion carried with Mr. Drinkhall abstaining from voting.

OTHER BUSINESS

North Conway Country Club (PID 218-32 & 34): Andrew Manning of H.E. Bergeron Civil Engineers appeared before the Board. Mr. Manning submitted that attached plan. Ms. Duane asked if the existing clubhouse would be eliminated. Mr. Manning answered in the affirmative. Mr. Manning stated there are some zoning issues as this area is in the floodplain and there are also some wetlands. Mr. Manning stated that they are trying to get a feel of their restrictions and want to see if this is even feasible. Ms. Duane stated if they meet all the environmental issues this would be a great proposal. The Board agreed.

Cranmore Mountain Resort (PID 214-84): Andrew Manning of H.E. Bergeron Civil Engineers appeared before the Board. Mr. Manning submitted the attached plan. Mr. Manning stated that Cranmore installed a new magic carpet lift. Mr. Manning stated that this is in the middle of a trail and is 240 feet in length. Mr. Manning asked if this requires a full site plan review. Mr. Manning stated that the greenspace is reduced by .00005 of a percentage. Mr. Webster asked if this would have been required to have a building permit. Mr. Irving answered in the affirmative.

Mr. Robinson stated that this is an enforcement issue. Mr. Robinson stated that these people install these things all over the country and know that they should have come to the Town. Mr. Irving stated to go through the process a full site plan review is necessary. Ms. Tobin stated that she sees the point, but doesn't see where were going to get by requesting a site plan. Mr. Webster stated if you grant any type of relief here then you set policy. Mr. Irving stated that the regulations should be changed before you enforce the policy.

Mr. Irving recommended following the regulations and expect a lot of waivers. Ms. Duane stated that she would like some time to review this situation. Mr. Manning stated that we are here to find out what we need to do to correct this situation. **Mr. Webster made a motion, seconded by Mr. Briggs, to table this for a 60-day non-enforcement period. Motion unanimously carried.**

Master Plan Workshops – Set Dates: The Board agreed to meet on Thursday, March 6 at 7:00 p.m. and Wednesday, March 19 at 3:00 p.m.

Meeting adjourned at 8:47 p.m.

Respectfully Submitted,

Holly L. Meserve
Recording Secretary

HEB

January 22, 2003

Mr. Tom Irving, Planning Director
Town of Conway
1634 East Main Street
Center Conway, NH 03813

Re: **Request for Conceptual Review**

Dear Mr. Irving,

On behalf of the North Conway Country Club (NCCC), H.E. Bergeron Engineers (HEB) is submitting a request for Conceptual Review by the Planning Board for a site development in North Conway village. The proposal is summarized as:

Conceptual Review of NCCC, Tax Map 218, Lot 33

The North Conway Country Club is reviewing the feasibility of constructing a new, year-round club house on the "Allard Field" parcel of land. The parcel is located on the western side of the Conway Scenic Railroad, south of the existing golf course. The new club house would generally consist of the same square footage of the existing club house, with improved parking facilities and accessory amenities.

Based on the latest Planning Board schedule, HEB requests the Conceptual Review be placed on the first regularly held public hearing in February, which is scheduled for February 13, 2003.

If you have any questions or would like to discuss the proposal, please feel free to contact me at 356-6936. Thank you for your time in attending to this request.

Sincerely,
H. E. Bergeron Engineers, P.A.

Andrew Manning, P.E.
Project Engineer

Cc: BHDP, HEB
File

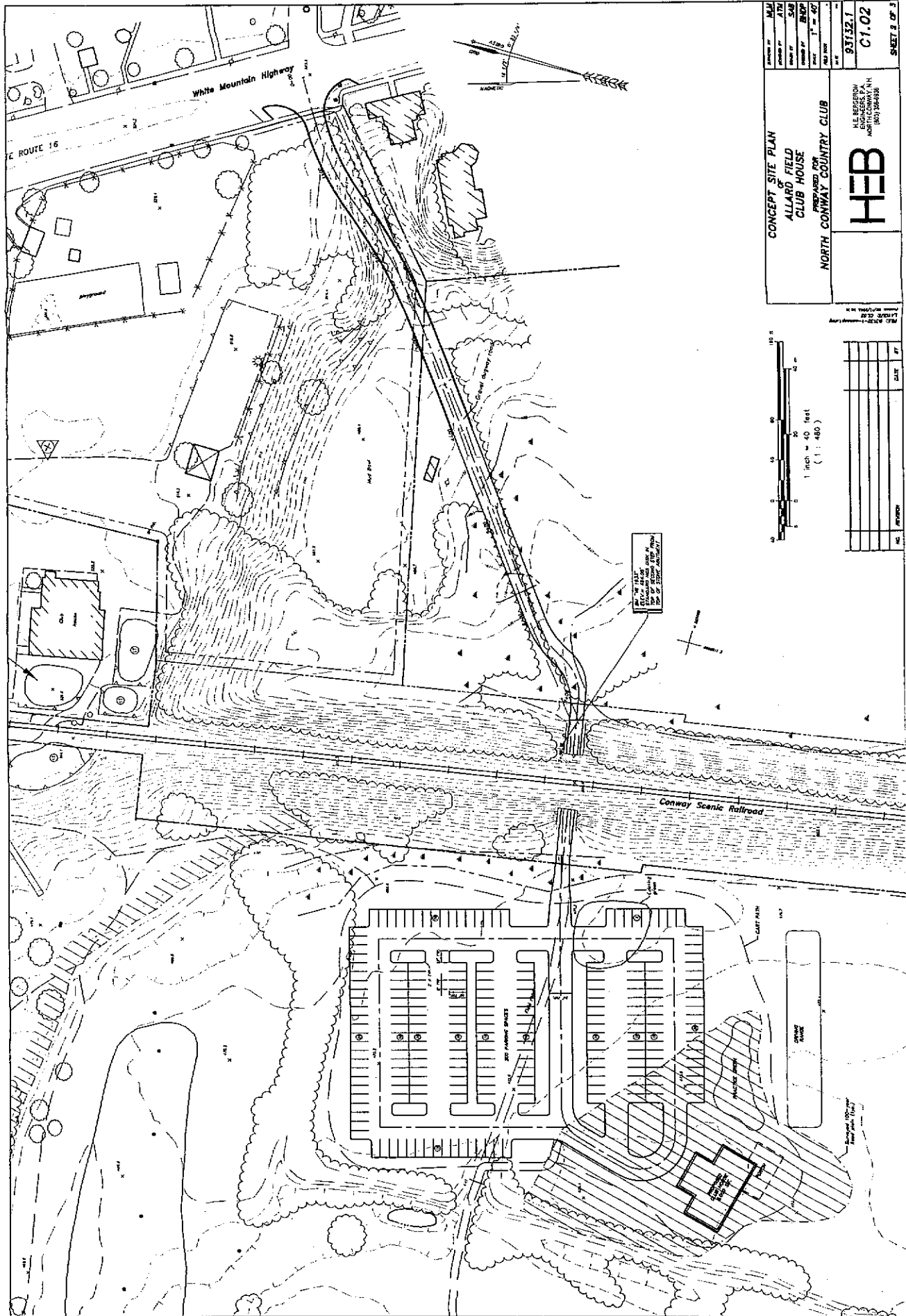

SHEET NO. 93132.1
 DATE 11-82
 DRAWN BY S.A.
 CHECKED BY S.A.
 PROJECT NO. 93132.1
 SCALE 1" = 40'
 SHEET 2 OF 3

CONCEPT SITE PLAN
 ALLARD FIELD
 CLUB HOUSE
 PREPARED FOR
 NORTH CONWAY COUNTRY CLUB

HEB
 H. B. BERGERON
 ENGINEERS, P.A.
 100 S. 10TH ST.
 ANNE ARBOR, MI 48103-2438

H. E. Bergeron Engineers

• Civil • Structural • Land Surveying

P.O. Box 440
2605 White Mountain Highway
North Conway, NH 03860
(603) 356-6936
(603) 356-7715 (fax)

65 W. Commercial Street
Portland, ME 04101
(207) 780-1100
(207) 780-1101 (fax)
www.hebcivil.com

HEB

January 27, 2003

Mr. Tom Irving, Planning Director
Town of Conway
1634 East Main Street
Center Conway, NH 03813

Re: **Request for Planning Board Review
Cranmore Mountain Resort**

Dear Mr. Irving;

On behalf of the Cranmore Mountain Resort, H.E. Bergeron Engineers (HEB) is submitting a request for review by the Planning Board of a minor site modification with the ski resort operations. The work is summarized as:

Review of Cranmore Mountain Resort, Tax Map 214 Lot 84

The Cranmore Mountain Resort installed a "Magic Carpet" ski lift to the main base lodge area and rerouted existing ski lifts to improve safety and operation of the mountain.

Based on the latest Planning Board schedule, HEB requests the review be placed on the first regularly held public hearing in February, which is scheduled for February 13, 2003.

If you have any questions or would like to discuss the proposal, please feel free to contact me at 356-6936. Thank you for your time in attending to this request.

Sincerely,
H. E. Bergeron Engineers, P.A.



Andrew Manning, P.E.
Project Engineer

Cc: BHDP, HEB
File

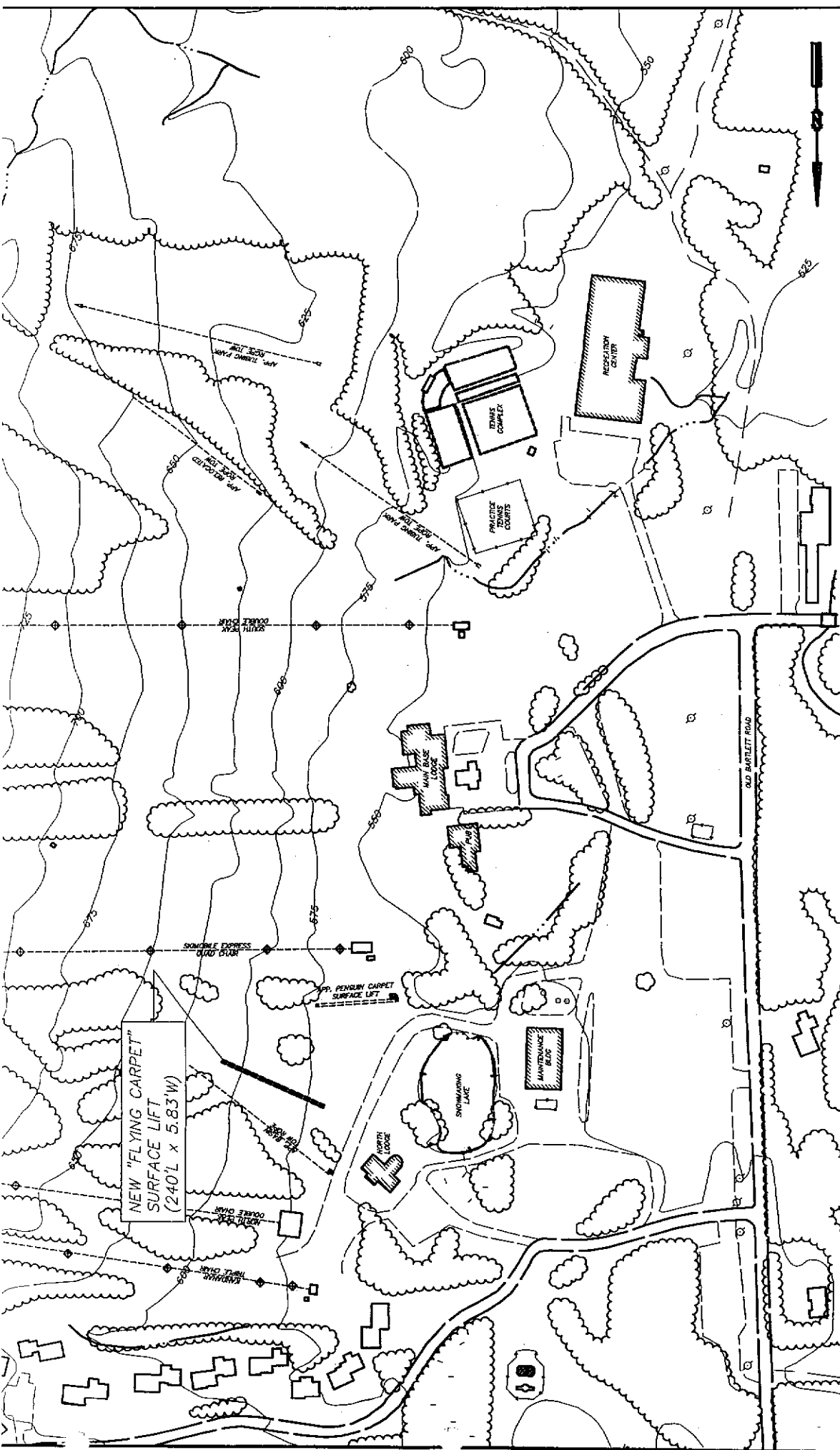

NEW "FLYING CARPET"
SURFACE LIFT
(240L x 5.83'W)

HEB
 H.L. BERGERSON
 ENGINEER, P.A.
 NORTH CAROLINA, N.C.
 (666) 368-6666

SKC-1
 DRAWN: ATM SCALE: 1"=200'
 DATE: 10 FEB 02 PROJ. # 88132

"FLYING CARPET" SURFACE LIFT
 SITE PLAN
 prepared for
 CRANMORE MOUNTAIN RESORT

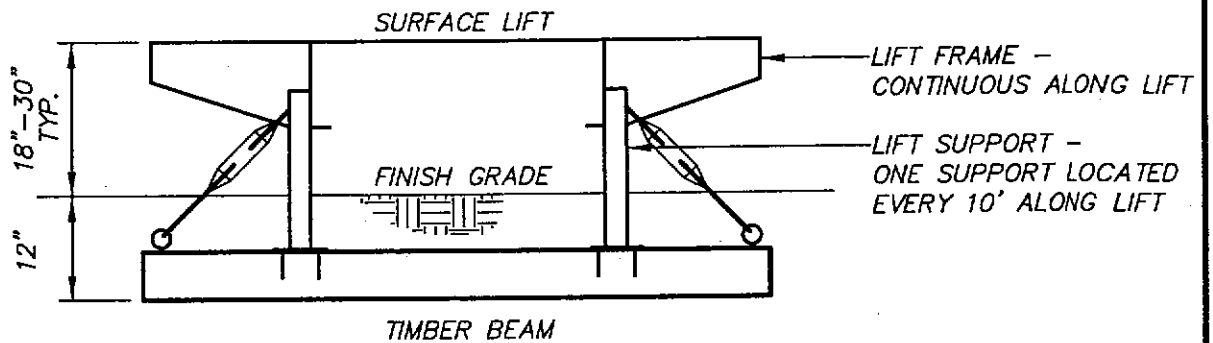

TYPICAL SECTION
NOT TO SCALE

HEB

H.E. BERGERON
ENGINEERS, P.A.
NORTH CONWAY, N.H.
(603) 356-8938

"FLYING CARPET" SURFACE LIFT
CROSS SECTION

prepared for
CRANMORE MOUNTAIN RESORT

SKC-2

DRWN: ATM SCALE: AS NOTED
DATE: 10 FEB 02 PROJ. # 98132